

MINIATURE SLIP CLUTCH

ADJUSTABLE, CONTINUOUS
CLAMP HUB TYPE

**TORQUE RANGE
UP TO 50 OZ. IN.**

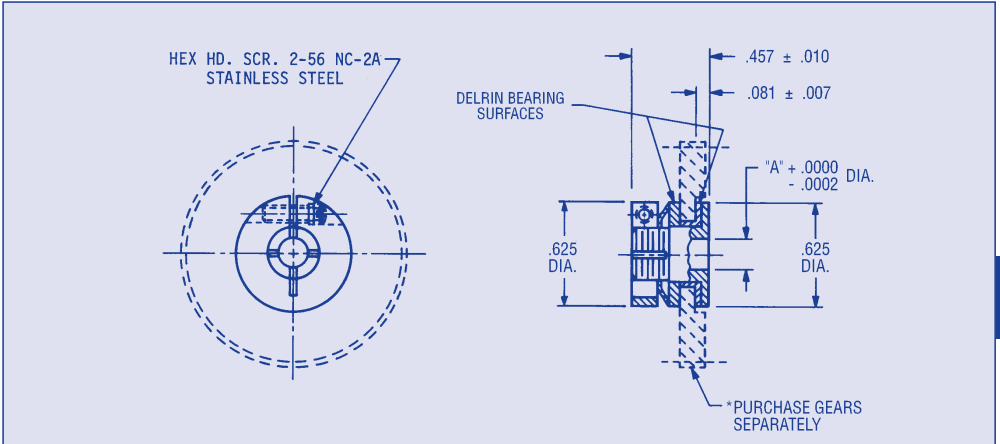

Material: Hub and Clamp – Anodized Aluminum
Clutch Face – Delrin
Spring Washer – Spring Steel, Cadmium Plated.

*Note: Gear mounting diameter .3746 $\begin{matrix} +.0000 \\ -.0005 \end{matrix}$

ORDER BY CATALOG NUMBER

Cat. No.	"A" Dia.	Torque Oz. In.
EUX-H6-12	.1250	0-50
EUX-H6-18	.1875	

* Note: Does not include a gear. Gears must be ordered separately. Please see catalog section "L" for a wide selection of hubless gears. .125 face with hubless gear when ordered with clutch will be recessed per phantom gear shown in the view.

For use with: Hubless gears. Chain sprockets. Timing belt pulley. Gear blanks.

UNIVERSAL LATERAL COUPLINGS

- Simultaneously accommodates up to 10° angular misalignment and up to .05" lateral misalignment
- Backlash free
- Set screw hubs
- No lubrication needed
- Electrically insulating
- Suitable for manual, sequence, or continuous operation

See product catalog number CQX-A1-1.

